

CLASS 124 · 126 · 128 · 1:

Super Sylon Flatwork Ironers

4-Roll 6-Roll 8-Roll 12-Roll

INSTRUCTION MANUAL

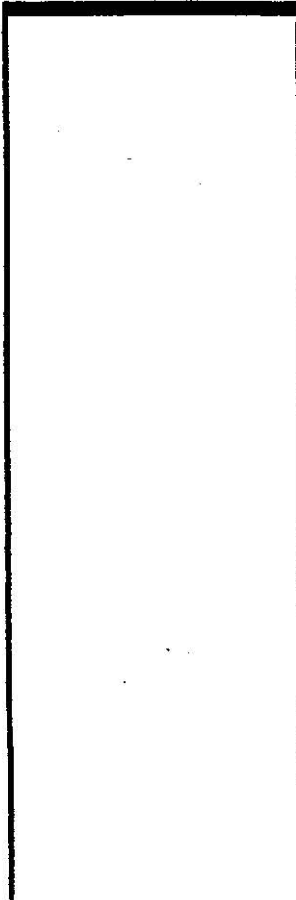

AMERICAN®

5050 Section Avenue
Cincinnati, OH 45212-2999

INSTALLATION · OPERATION · MAINTENANCE INSTRUCTIONS

American

SUPER - SYLON

Flatwork
Ironer

CONTENTS

DESCRIPTION	2
DATA and SPECIFICATIONS	4
INSTALLATION	5
Uncrating	
Foundation	
Location	
Squaring Frames	
Leveling	
Piping Connections	
Electrical Connections	
Apron Guide Roll	
Installing Aprons	
Installing Padding	
Setting Pressure Screws	
OPERATION	12
Pressure Indicator and Control	
Ribbon Feed	
Apron Tension Control	
Heating Chests	
Starting and Stopping	
Pressure Control	
Feeding	
ROUTINE MAINTENANCE	15
Lubrication Chart	
Cleaning Chests	
Inspection	
SPECIAL MAINTENANCE	21
Installing Clipper Lace Apron	
Adjusting Clutch	
Apron Adjustment	
Trouble Shooting	

IMPORTANT

The purpose of this manual is to acquaint you fully with this equipment, and to tell briefly and clearly how it should be installed, operated and maintained. The machinery is built according to highest manufacturing standards and has been thoroughly inspected

and tested at the factory before shipment. It should give you years of efficient, trouble free service *providing the instructions herein are followed*. Therefore, this manual should always be kept available for those who may need it.

READ THIS MANUAL - FOLLOW THE INSTRUCTIONS

DESCRIPTION

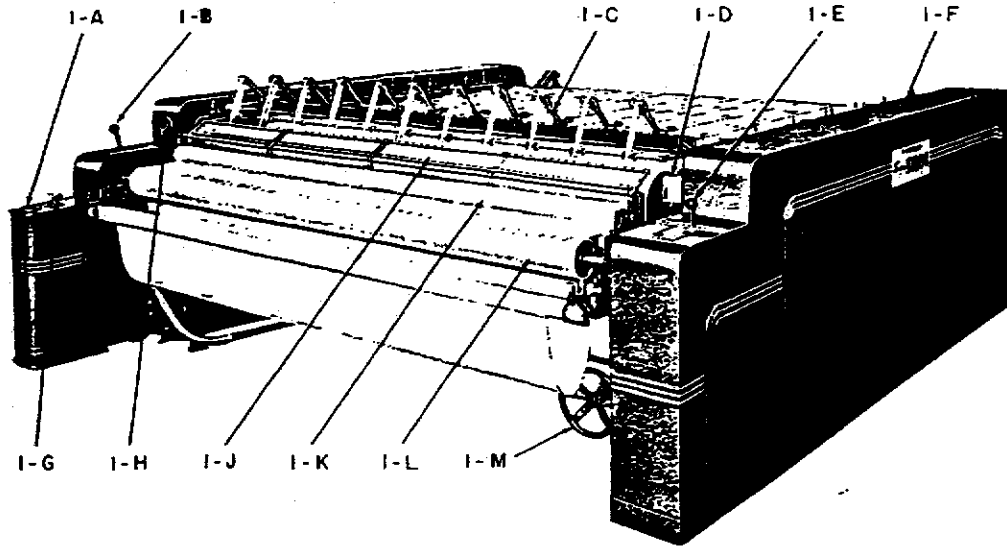

FIGURE 1 - FEED END OF 8-ROLL FLATWORK IRONER

ITEM	DESCRIPTION	ITEM	DESCRIPTION	ITEM	DESCRIPTION
1 - A	Start and Stop Button	1 - E	Pressure Control Lever	1 - J	Finger Guard
1 - B	Clutch Lever	1 - F	R.H. Main Guard	1 - K	Doffer Roll
1 - C	Spool Arm Assembly	1 - G	Speed Control	1 - L	Ribbon Drive Roll
1 - D	Pressure Indicator	1 - H	Speedometer	1 - M	Raising Rig Hand Wheel

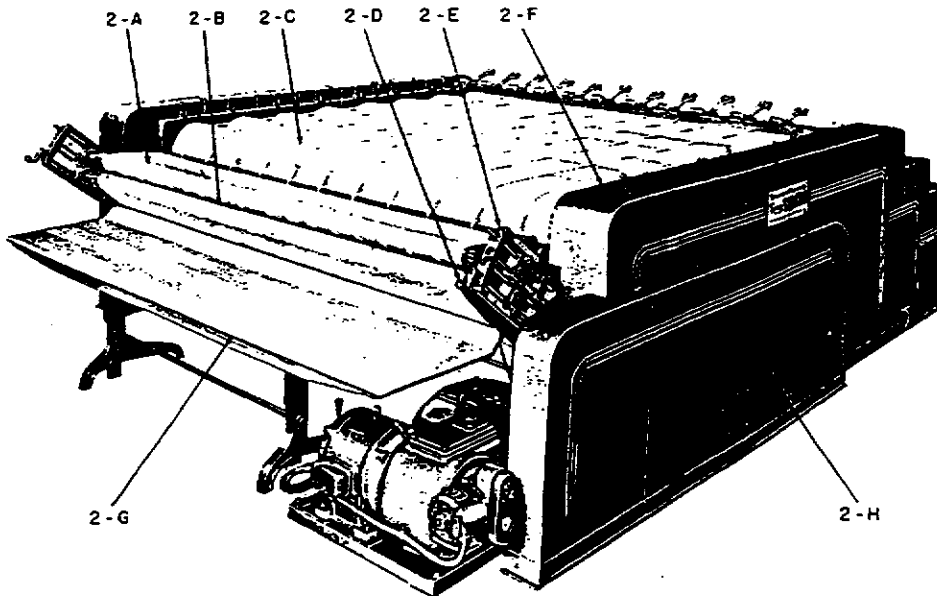

FIGURE 2 - DELIVERY END OF 8-ROLL FLATWORK IRONER

ITEM	DESCRIPTION	ITEM	DESCRIPTION
2 - A	Upper Apron Spiral Roll	2 - E	Spiral Roll Brkt. Assembly
2 - B	Lower Apron Spiral Roll	2 - F	L.H. Main Guard
2 - C	Ironer Rolls	2 - G	Delivery Table
2 - D	Apron Tension Handle	2 - H	Belt Guard

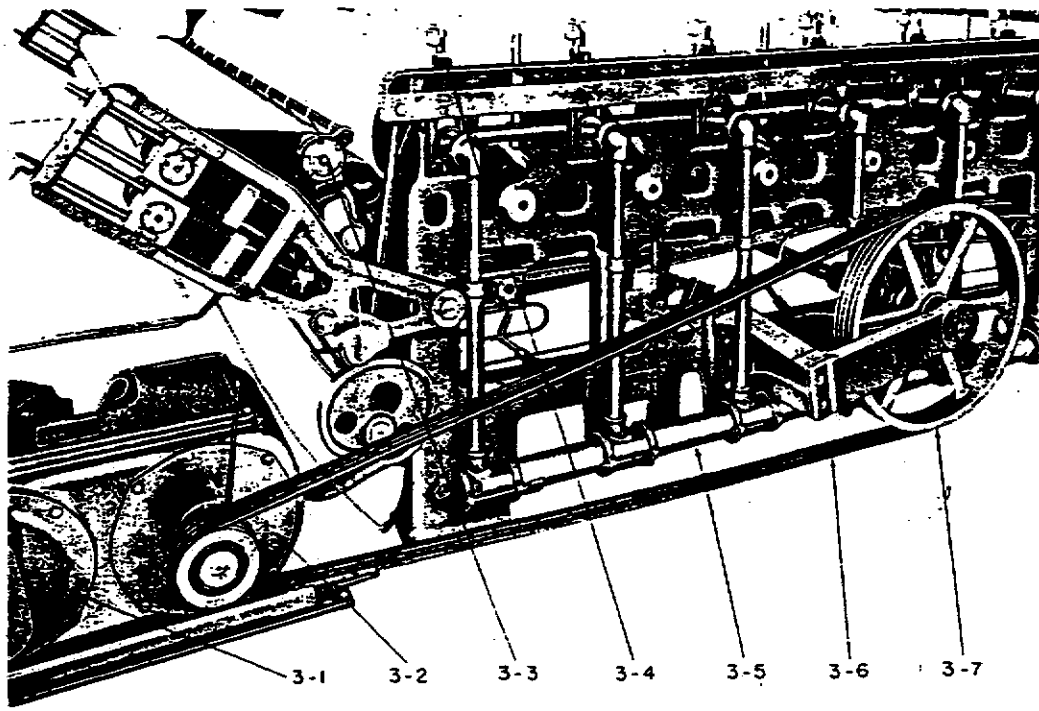

FIGURE 3 - LEFT HAND SIDE VIEW OF 8-ROLL FLATWORK IRONER

ITEM	DESCRIPTION	ITEM	DESCRIPTION
3-1	Drive Motor	3-5	Steam Manifold
3-2	Speed Changer	3-6	Multiple V-Belts
3-3	Tension Roll	3-7	Large Sheave
3-4	Pressure Screw		

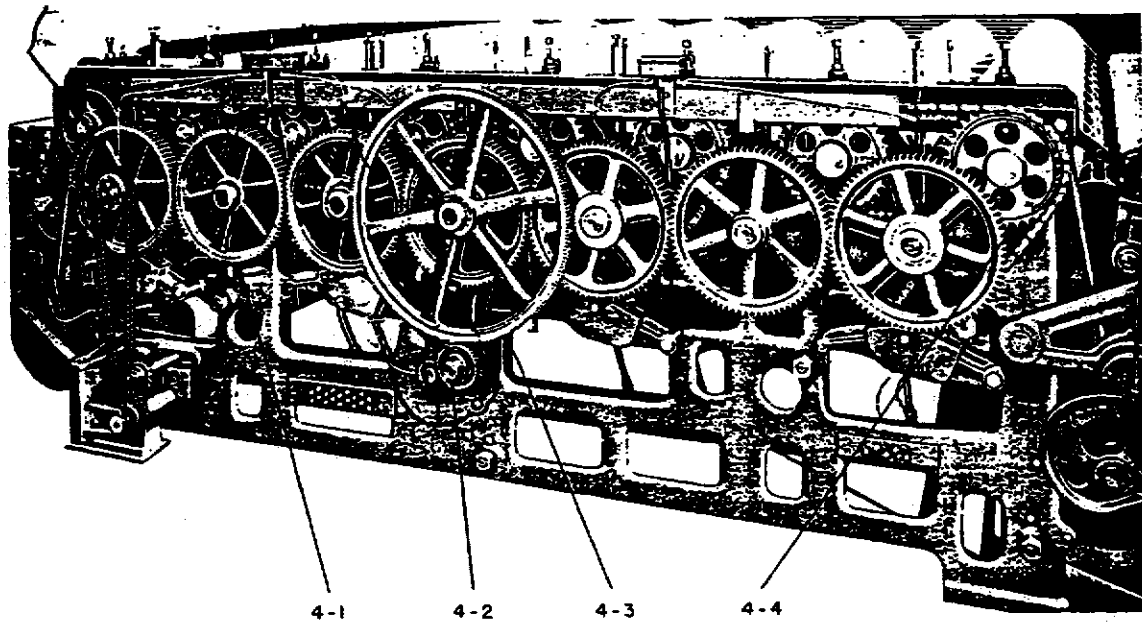

FIGURE 4 - RIGHT HAND SIDE VIEW OF 8-ROLL FLATWORK IRONER

ITEM	DESCRIPTION	ITEM	DESCRIPTION
4-1	Spur Gear	4-3	Large Herringbone Gear
4-2	Main Drive Shaft and Pinion	4-4	Sprockets

DATA and SPECIFICATIONS

MACHINE DATA

NO. OF ROLLS	4-ROLL			6-ROLL		8-ROLL		12-ROLL
	100"	110"	120"	110"	120"	110"	120"	120"
Length	100"	110"	120"	110"	120"	110"	120"	120"
Ironer Size								
Width	145"	156"	166"	156"	166"	156"	166"	167"
Depth	154"	154"	154"	186"	186"	218"	218"	283"
Height	55"	55"	55"	55"	55"	55"	55"	55"
Approx. Shipping Wt. (Lbs.)								
Cellulose Padding	16100	17000	17900	24000	25000	29500	30600	43600
Hamilton Spring Padding	17100	18100	19100	25650	26800	31700	33000	47200
Steam Connections								
Inlet	1-1/2"	1-1/2"	1-1/2"	2"	2"	2"	2"	3"
Return	1-1/2"	1-1/2"	1-1/2"	1-1/2"	1-1/2"	1-1/2"	1-1/2"	2-1/2"
Steam Pressure (PSI)								
Minimum	100	100	100	100	100	100	100	100
Maximum	125	125	125	125	125	125	125	125
Steam Consumption (Pounds per Hour)								
Standard Drive	390	390	390	585	585	780	780	1170
High Speed Drive	---	---	---	---	---	960	960	1440
Speed Range (Ft. per Min.)								
Standard Drive	17 to 52	17 to 52	17 to 52	24 to 72	24 to 72	30 to 90	30 to 90	30 to 90
High Speed Drive	---	---	---	---	---	37 to 110	37 to 110	37 to 110
Drive Motor								
Standard Drive	3 H.P.	3 H.P.	3 H.P.	5 H.P.	5 H.P.	7½ H.P.	7½ H.P.	10 H.P.
High Speed Drive	---	---	---	---	---	10 H.P.	10 H.P.	15 H.P.
Vacuum Exhaust Motor (With Ham. Spring Pad.)	1 H.P.	1 H.P.	1 H.P.	1 H.P.	1 H.P.	1 H.P.	1 H.P.	1 H.P.
Vacuum Exhaust Conn.	4"	4"	4"	4"	4"	4"	4"	4"

ELECTRICAL SPECIFICATIONS

Motors are furnished with voltages indicated, at 3 phase, and 60 cycle. Wire Size is given for a maximum run of 50 ft.

MOTOR	VOLTAGE	WIRE SIZE (AWG GAUGE)	DISCONNECT SWITCH	FUSES	CIRCUIT BREAKER
3 H.P.	208-240	#10	60 Amp.	35 Amp.	30 Amp.
	440	#12	30 Amp.	20 Amp.	20 Amp.
5 H.P.	208-240	# 8	60 Amp.	60 Amp.	50 Amp.
	440	#12	30 Amp.	30 Amp.	30 Amp.
7½ H.P.	208-240	# 6	100 Amp.	80 Amp.	70 Amp.
	440	#10	60 Amp.	40 Amp.	40 Amp.
10 H.P.	208-240	# 4	100 Amp.	100 Amp.	90 Amp.
	440	# 8	60 Amp.	60 Amp.	50 Amp.
15 H.P.	208-240	# 2	200 Amp.	150 Amp.	125 Amp.
	440	# 6	100 Amp.	80 Amp.	70 Amp.

EXTRA EQUIPMENT (OPTIONAL)

Shakeout Poles & Stands

Board Shakeout & Feeding Device

Screen Guard Over Rolls

PIPING CONNECTIONS

STEAM RETURN - The steam manifold for the ironer is located on the right-hand side facing the rear end. Steam connection must be made at the rear or delivery end of the machine. The manifold connections, are therefore, arranged for it to pitch downhill toward the front or feed end of the machine. Since the front end of the steam manifold is the low point, a 1/2" bucket trap should be connected at this point, discharging into the return system.

The return manifold is located on the left-hand side of the machine when facing the feed end. The return manifold also pitches toward the front or feed end of the machine. Therefore, the bucket trap to be installed, should be connected at this point. This line should be by-passed so trap can be removed for cleaning.

The main steam inlet valve should be by-passed with a 1/2" line for warming up purposes.

VACUUM ATTACHMENTS - On those ironers equipped with Hamilton Spring-Padding, the left-hand cover has been cut out to permit the exhaust line to be run through the cover and to the outside of the machine.

Be sure to remove the 3/8" drain plug from the bottom hole in the fan housing, connect a standard 3/8" pipe to this hole and drain to a suitable sewer or gutter.

ELECTRICAL CONNECTIONS

The ironer is furnished with wiring in conduit between the motor and controller. Terminals, properly tagged, are provided for connection of the control and service leads. *These tags should never be removed, even after wires are connected.* Wiring diagram will be found inside the cover of the control box.

APRON GUIDE ROLLS

See Figure 7 for position of guide rolls, then refer to Figure 6 for installation. For convenience in shipping, the thrust bearing (6-C) is placed on the 5-7/8" long roll shaft between the shoulder and set collar (6-B). The positions of thrust bearing and set collar must be interchanged on the roll shaft for proper operation. Correct procedure for installing guide roll assembly is as follows:

- 1 - Loosen set screw in set collar (6-B), and re-

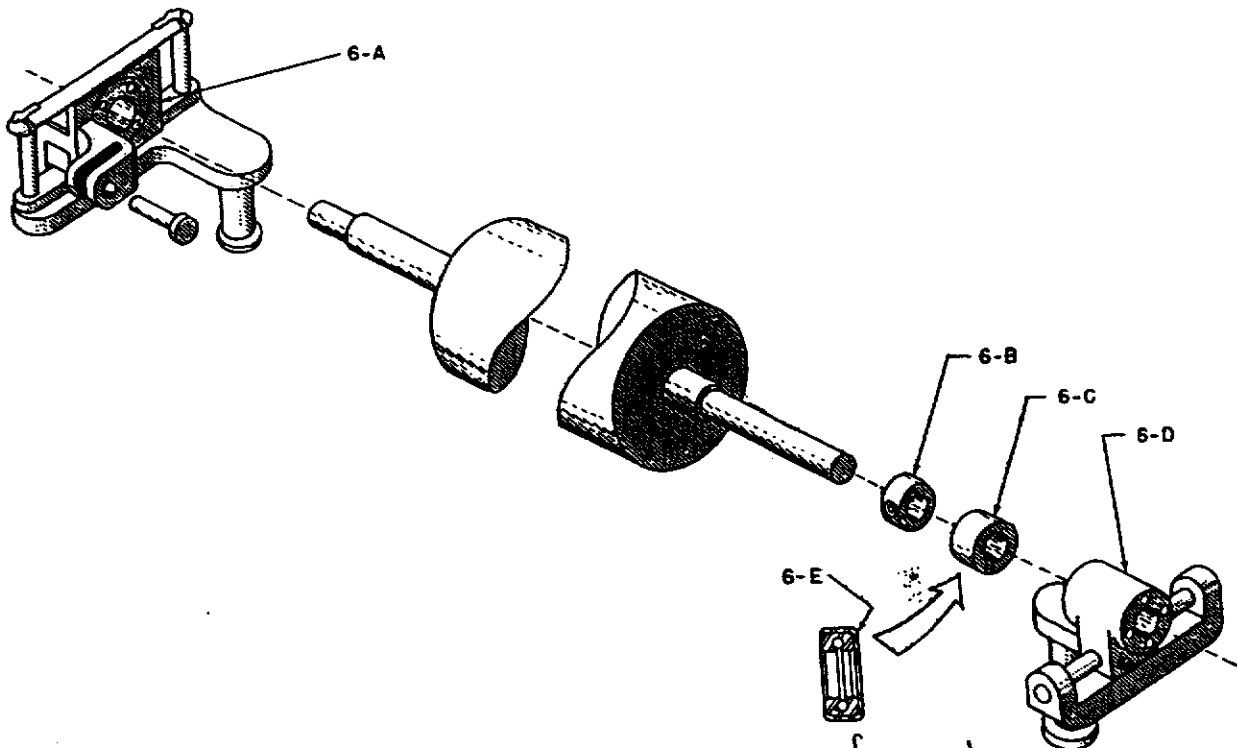

FIGURE 6 - GUIDE ROLL ASSEMBLY

move collar and thrust bearing (6-C) from roll shaft.

2 - Replace set collar on same end of roll shaft (end with 5-7/8" long shaft), but do not tighten set screw at this time.

3 - Place thrust bearing on same end of roll shaft with outer band (6-E) facing outward. It is important that thrust bearing be installed in this manner.

4 - Insert end of roll, with set collar and thrust bearing attached, as far as possible in pivot end of guide roll box assembly (6-D).

5 - Insert opposite end of roll in moveable end of guide roll box assembly (6-A) leaving 1/8" space between shoulder on shaft and roll box.

6 - Move set collar and thrust bearing against inner plate of bearing in pivot end of guide roll box assembly. Tighten set screw in set collar.

INSTALLING APRONS

Before installing aprons, ironing pressure must be released by turning hand wheel at the feed end of ironer. Also spiral rolls must be in lowest position in their brackets.

Install upper apron first, start at delivery end of ironer. Lie down under ironer and thread it through ironer as shown in Figure 7. Guide apron by hand until lead end is returned to delivery end of ironer.

Match blue lines on aprons, then insert steel wire through the clips on the adjoining ends and bend ends of wire under to hold it in place.

MATERIAL USED ON FLATWORK IRONERS

APRONS				
No. of Rolls	Apron	100" #6 Duck	110" #5 Duck	120" #5 Duck
4	Upper	16'0" x 100"	16'0" x 110"	16'0" x 120"
	Lower	19'1" x 100"	19'1" x 110"	19'1" x 120"
6	Upper		21'5" x 110"	21'5" x 120"
	Lower		24'4" x 110"	24'4" x 120"
8	Upper		26'8" x 110"	26'8" x 120"
	Lower		29'3" x 110"	29'3" x 120"
12	Upper			37'8" x 120"
	Lower			40'0" x 120"
RIBBONS				
18" Ribbon Feed (Woven endless webbing)		100"	110"	120"
Ribbons	2-1/2x40" (Size)	37 each	41 each	45 each
TAPE DEVICES				
American Cloth	Size 1-1/8" x 100'0"	4, 6, & 8-Roll	3-Pieces Tape	
		12-Roll	6-Pieces Tape	
MISCELLANEOUS				
Bibb	1-Piece #12 Duck	50 x 102"	50 x 112"	50 x 122"
Ribbon Roll	1-Piece #12 Duck	21 x 101"	21 x 111"	21 x 121"

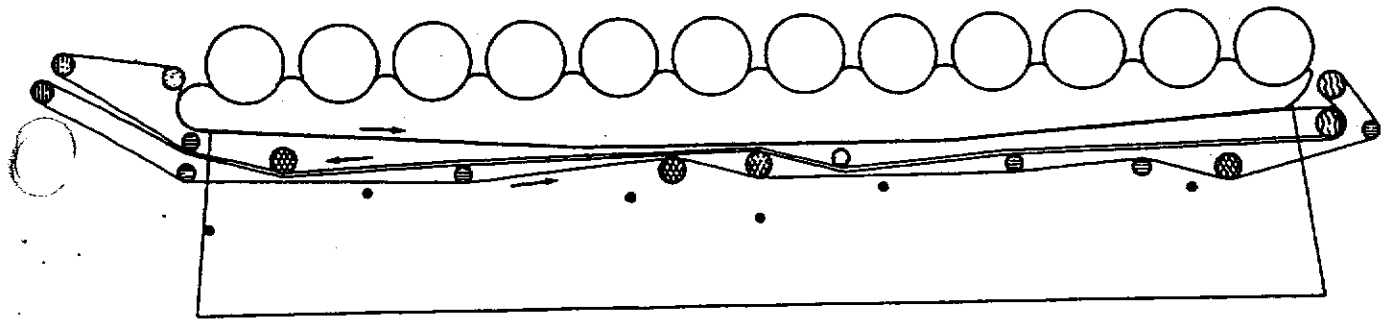

12 - ROLL

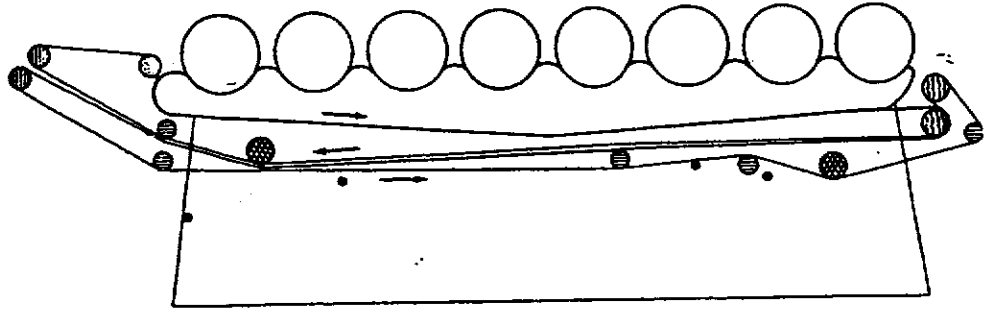

8 - ROLL

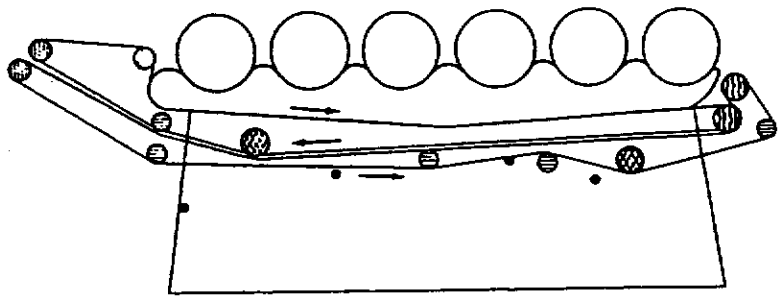

6 - ROLL

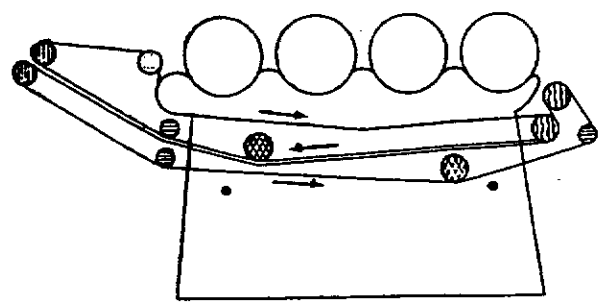

4 - ROLL

KEY







-  SPIRAL ROLLS
-  TENSION ROLL
-  IDLER ROLLS
-  GUIDE ROLLS
-  DRIVE ROLLS
-  TIE RODS

FIGURE 7 - APRON TRAVEL

Install lower apron in same manner. Do not tighten aprons until ironer is heated. Then apply only enough tension to upper apron to keep top side against bottom of steam chests. If upper apron sags at center it is too loose. Apply just enough tension to lower apron to keep it smooth and taut, so that it tracks properly. Apron adjustment is described in the Special Maintenance Section.

INSTALLING PADDING

CELLULOSE PADDED ROLLS

Before applying padding, lubricate ironer according to instructions under "ROUTINE MAINTENANCE". Heat the ironer and apply "light pressure" to machine manually. Apply padding as follows:

CELLULOSE PADDING

TYPE OF MATERIAL	Dimensions of Material		
	100"	110"	120"
Muslin	81 x 102"	81 x 112"	81 x 122"
5/8" Knitted Padding	80 x 98"	80 x 108"	80 x 118"
Muslin	81 x 102"	81 x 112"	81 x 122"
Coverdax	90 x 104"	90 x 114"	90 x 124"

- 1 - Start with No. 1 roll and glue a 4 to 6-inch wide strip of the leading end of muslin binder to the bare roll. *Be careful not to get glue on Ironer Chests.*
- 2 - Glue the muslin binder in the same manner to each of the rolls in succession.
- 3 - Start the ironer and rotate rolls so that glued portion of muslin binder is between rolls and chests. Stop ironer and leave rolls in this position for approximately 15 minutes, so that glue may partially set.
- 4 - Start ironer and wind the muslin binder on the rolls, making sure cloth winds straight on rolls.
- 5 - Stop ironer and unwind two-thirds of the outside wrap of muslin binder. Insert leading

end of the 5/8" knitted padding under the wrap of muslin binder.

- 6 - Start ironer under light pressure and wind knitted padding on No. 1 roll.
- 7 - Stop ironer and unwind two-thirds of the outside wrap of knitted padding on No. 1 roll. Insert leading end of second piece of muslin under this wrap of knitted padding.
- 8 - Start ironer under light pressure and wind second piece of muslin on No. 1 roll, *making sure to remove all wrinkles.*
- 9 - In same manner, apply 5/8" knitted padding, and second piece of muslin to the other rolls in succession.
- 10 - The COVERDUX can be applied at this time, or the ironer can be run for several days to pack in the padding before applying the cover cloths. Apply the COVERDUX by starting with No. 1 roll and lapping back about two-thirds of the last wrap of the second piece of muslin. Then insert leading end of COVERDUX under the wrap of muslin.
- 11 - Start ironer and wind COVERDUX smoothly on roll.
- 12 - In same manner, apply COVERDUX to each succeeding roll.
- 13 - Final minimum diameter of padded roll should be 13-1/8"

HAMILTON SPRING PADDED ROLLS

Before applying padding, lubricate ironer as outlined in Routine Maintenance Section.

The ironers are shipped with the asbestos padding applied to the Hamilton Spring padded rolls. Therefore, steps 1, 2, 3, 4 & 5 are omitted for initial padding, and used only when repadding. With steam to chests "ON" and ironer in "OFF" pressure position, proceed as follows: (See Figure 8). Refer to chart on "Hamilton Spring Padded Rolls" for type of material and size of material to be put on each roll.

- 1 - Arrange asbestos padding behind roll No. 1, then place the asbestos next to the springs on roll, and secure it to roll by cutting slots one inch long (in line with feed) in the asbestos, to fit over each of the hook fasteners.

HAMILTON SPRING PADDING

TYPE OF MATERIAL	Dimensions of Material		
	100"	110"	120"
ME 2909 Asbestos	81 x 100"	81 x 110"	81 x 120"
#18 Gauge Copper Wire	250"	250"	250"
5/8" Knitted Padding	40 x 98"	40 x 108"	40 x 118"
Coverdux	90 x 104"	90 x 114"	90 x 124"

Leading end of asbestos should be six inches ahead of row of springs in which the special hook fasteners are located.

2 - Stretch asbestos along length of roll so it extends an equal distance over each end. It is very important that correct width of covering be used for the different size ironers.

3 - Attach the asbestos to the hook fasteners by starting from center of roll and working toward both ends. Be careful to eliminate all wrinkles in the asbestos.

4 - Bind down the six-inch lap with #18 gauge copper wire. Run wire the entire length of roll in saw-tooth fashion from hook fasteners to springs, by dropping wire down to catch two springs in the first row ahead of the six-inch lap. Be sure to draw wire tight between springs and hook fasteners. See Sketch "B".

5 - Start ironer and wind asbestos on roll.

6 - Unwrap asbestos on #1 roll until you can see the starting point of the asbestos on the springs. Then feed in 5/8" knitted padding with leading edge of knitted padding even with the leading edge of asbestos and wind padding and asbestos covering smoothly onto roll, removing all wrinkles. The asbestos should be 1 inch short of two complete turns when this operation is completed. If this is not the case, cut the asbestos until it is 1 inch short of two complete turns. The knitted padding should be entirely covered with asbestos when finished.

Apply pressure until #1 roll pin becomes loose.

Unwrap 18 to 20 inches of top layer of asbestos, insert Coverdux and wind on #1 roll.

9 - Follow same procedure for each roll. During the process of padding be sure that the roll box pins remain loose in the rolls that have been previously padded. Should any tighten, apply a little more pressure to loosen them.

10 - Final minimum diameter of padded roll should be 13-1/8".

SETTING PRESSURE SCREWS

The following explanation pertains to the 8-Roll Ironer. However, setting pressure screws on 4, 6 and 12-Roll Ironers is relatively the same. Before setting pressure screws, run ironer for thirty minutes, then:

1 - Apply pressure until spiral roll brackets reach point of maximum lift on the large cams. This is not quite two-thirds of the full travel of the key in rear pressure shaft. Full travel of the key is from full "OFF" pressure where it is at top of shaft, to full "ON" pressure where it is at bottom of shaft.

2 - Check small pins (Figure 8) at each end of No. 1 roll, and see if they are loose. If they are not loose, apply pressure gradually until they are. Do the same for each succeeding roll. Do not apply more pressure than is necessary to free these pins.

3 - With ironer running and pressure still applied, install screws for No. 1 roll on both sides, turning screws down evenly and as far as possible by hand. Install pressure screws for other rolls in same manner.

4 - With all pressure screws set hand-tight, tighten lock nuts on pressure screws of 8th roll. Then, using wrench:

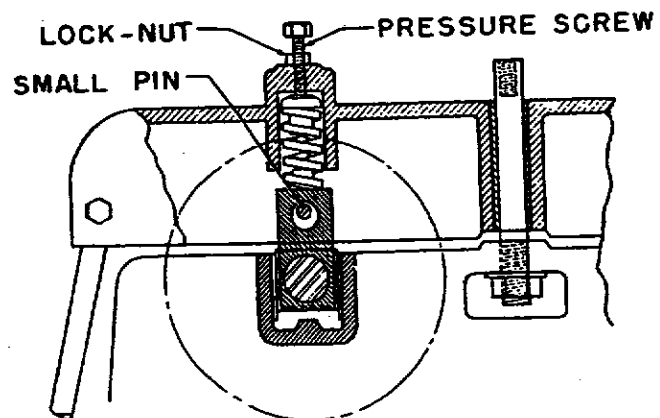
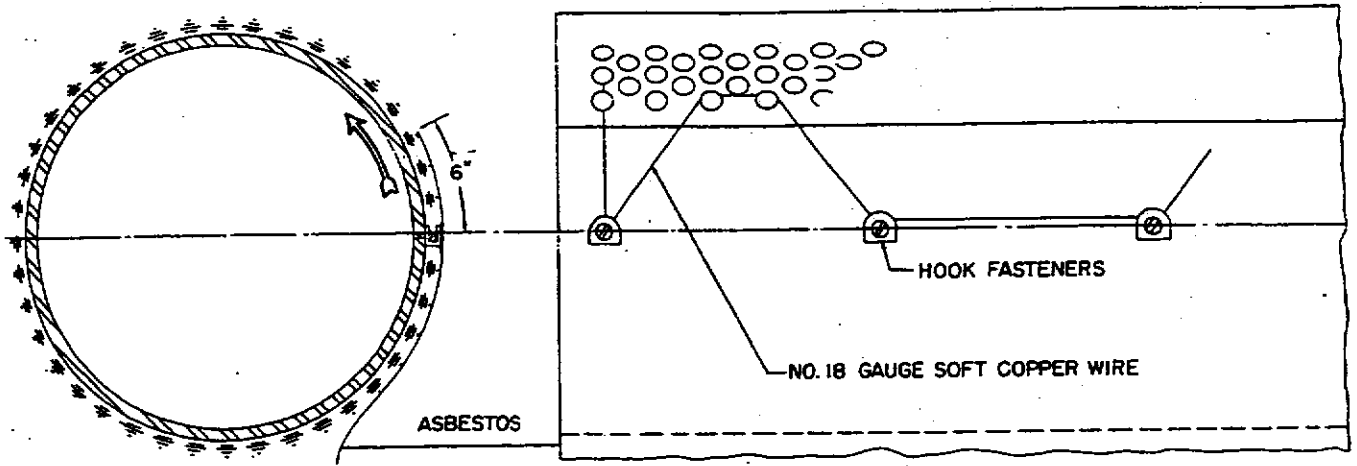
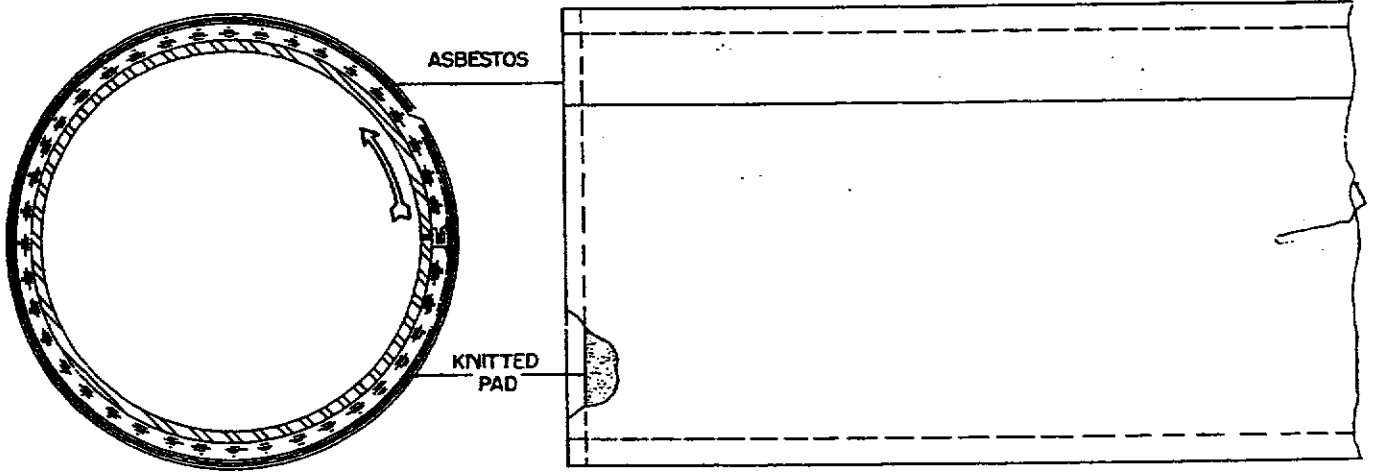

FIGURE 8 - SETTING PRESSURE



"A"



"B"

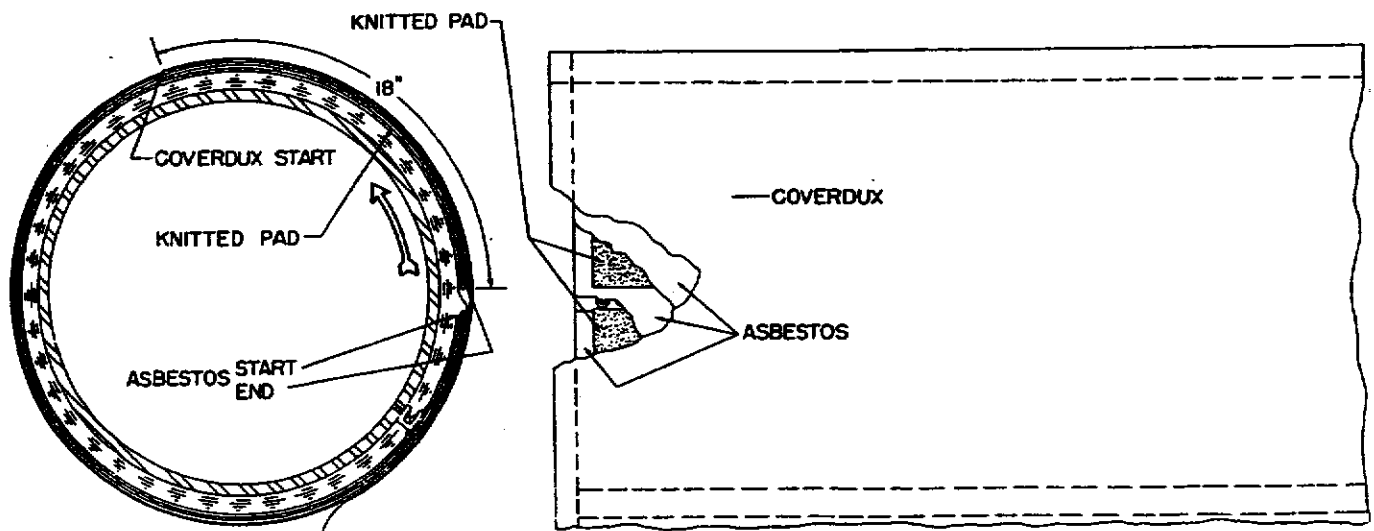

"C"

FIGURE 9 - APPLICATION OF HAMILTON SPRING PADDING

Turn Roll #7 pressure screws 1/6th turn*

Turn Roll #6 pressure screws 1/3rd turn

Turn Roll #5 pressure screws 1/2 turn

Turn Roll #4 pressure screws 2/3rd turn

Turn Roll #3 pressure screws 5/6th turn

Turn Roll #2 pressure screws one full turn

Turn Roll #1 pressure screws 1-1/6th turns

* *In making the 1/6th turn, the hexagon heads of the pressure screws can be used as a guide, as there are six flat sides on the heads. After turning pressure screws, be sure to tighten lock nuts.*

On 12, 6 and 4-Roll Ironers the pressure screw setting is made in the same manner as the 8-Roll setting. In each case, after the pressure screws are set hand-tight, start with next to the last roll and set remaining pressure screws in increments of 1/6th of a turn.

- 5 - With the pressure at this point, adjust the pressure indicator to the top mark on the face of the indicator. Then apply sufficient pressure to move pointer from top mark to lower mark, which is labeled "IRONING PRESSURE". Instruct your operator to keep pressure at this point. The advantage of this indicator is that you do not have to remember any setting on dial type indicator and you will not have to check any roll box pins for correct pressure. You merely have to run the pressure on until indicator lines up with the bottom mark.

OPERATION

The ironer is now ready for operation, but before starting it in production, careful attention should be given to the following features in order to be familiar with the functions of the various attachments and methods of operation.

PRESSURE INDICATOR AND CONTROL

The pressure indicator records variations in ironing pressure between the padded rolls and steam chests. A pointer extending through a slot in the face of the pressure indicator is pivoted from a bracket located on the pressure bar. The indicator pointer has a set screw which rides on the bearing box of the first padded roll. Any movement of the pressure bar in relation to the rolls is thereby registered by the pointer.

When proper ironing pressure is applied, the pointer registers with an indicating line plainly marked "IRONING PRESSURE" on the pressure indicator. If proper ironing pressure is not being applied, the pointer will not register with the indicating line.

A second pointer, at the right side of the pressure indicator, registers with fractional inch graduations from "0" (indicating pressure "ON"), to a 3-inch mark indicating that the rolls are

raised maximum distance from the chests. Position of this pointer indicates distance the rolls are out of pressure.

Ironing pressure is applied and released by moving Pressure Control Lever which operates the Roll-Raising Device. By means of this lever the rolls can be raised 3 inches from the chests when ironer is idle, or for repadding. Releasing or applying roll pressure simultaneously releases or applies tension of the ironer aprons.

The ironers are driven by a heavy duty, horizontal motor mounted on a floor base at the delivery end of ironer. Multiple V-belts from the motor sheave, drive a large sheave. When the clutch is engaged, the sheave drives a main drive shaft which extends to opposite side of ironer.

When mechanical speed changer is furnished, it is direct-driven from a constant speed motor. V-belts from the speed changer drive the large sheave on the ironer.

Main drive shaft of the ironer has a Herringbone pinion, keyed to its right end. The pinion meshes with a Herringbone gear which is compounded with a spur gear that drives a train of similar spur gears. Alternate gears in the train are each

compounded with a sprocket which drives sprockets on each two padded rolls through a separate roller chain. Tension of the roller chains is maintained by spring-actuated idler sprockets mounted in housings which are pivotally attached to the right frame of ironer.

RIBBON FEED

Linens are fed into ironer by placing leading edge on full-width ribbon feed. Padded doffer roll rests on the ribbon feed so that travel of the feed ribbons causes it to rotate. The doffer roll keeps work stretched taut between ribbon feed and the first padded roll.

A perforated, steel finger safety guard extends full width of the ribbon feed. It is connected to the drive clutch of the ironer so that slightest touch of operator's hands against it automatically stops ironer.

APRON TENSION CONTROL

Normal tension of the aprons is controlled by tension brackets, one mounted at each side of the delivery end of the ironer. Separate spiral rolls for the aprons are mounted in spring-held bearing boxes in the tension brackets. Pressure exerted by the springs against the bearing boxes maintains proper tension on the aprons during operation of the ironer.

Tension of the aprons beyond normal variations can be quickly adjusted by means of a hand crank on each of the tension brackets.

The spiral rolls in the tension brackets have double spiral ridges on their surfaces, running outward from the center to the ends. As the aprons travel over these rolls, the spiral ridges tend to spread the aprons and prevent them wrinkling. The spiral rolls also trip off any work that may cling to the aprons.

Corrugated friction spools are mounted on opposite ends of the spiral rolls. These spools are connected by chains to a lever and counter-weight mechanism, attached to sliding bearing boxes on one end of each of two guide rolls over which the aprons travel. Should the aprons track to one side or the other on the spiral rolls, the edges of the aprons run onto the friction spools and rotate them. Rotation of the spools then automatically shifts the position of the sliding bearing boxes on the ends of the apron guide rolls. This immediately straightens travel of the

aprons to keep them tracking properly and running true.

HEATING CHESTS

- 1 - Open valve in by-pass line around main steam supply valve. This will permit the chests to heat gradually.
- 2 - For approximately ten minutes open valve in condensate line by-passing steam trap.
- 3 - Close by-pass valve in condensate line. Steam trap is now operative.
- 4 - After thirty to forty-five minutes, open the main steam supply valve and close the valve in the by-pass line around this valve.

NOTE: Do not run work through ironer until chests are thoroughly heated.

STARTING AND STOPPING

- 1 - STANDARD - DRIVE IRONER
A.C., four-speed motor.
 - (a) Before starting Ironer be sure the pressure is "OFF" (See "PRESSURE CONTROL").
 - (b) Set control for lowest speed.
 - (c) Disengage clutch by pulling shifter lever towards operator.
 - (d) Depress "START" button.
 - (e) Engage clutch by pushing shifter lever away from operator.
 - (f) Set control for desired speed.
 - (g) Apply pressure as described in paragraph on "PRESSURE CONTROL".

To stop ironer, pull shifter lever towards operator, or push finger guard towards rear of ironer. This permits motor to continue running, and ironer can be restarted by simply reengaging clutch as described in paragraph (e) above. To stop the drive motor and vacuum-exhauster motor, depress the "STOP" button.

- 2 - STANDARD - DRIVE IRONER
D.C., variablespeed motor.

- (a) Before starting ironer be sure the pres-

sure is "OFF" (See "PRESSURE CONTROL").

- (b) Set field rheostat for lowest speed.
- (c) Disengage clutch by pulling shifter lever towards operator.
- (d) Depress "START" button on push-button station.
- (e) Engage clutch by pushing shifter lever away from operator.
- (f) Set field rheostat for desired speed.
- (g) Apply pressure as described under "PRESSURE CONTROL".

To stop the ironer, pull shifter lever towards operator, or push finger guard towards rear of ironer. This permits motor to continue running, and ironer may be restarted by simply reengaging the clutch.

To stop the drive motor and vacuum exhaustor motor, depress the "STOP" button on the push-button station.

OPTIONAL - DRIVE IRONER

Mechanical speed changer, A.C. and D.C.

- (a) Before starting ironer be sure the pressure is "OFF".
- (b) Disengage clutch by pulling shifter lever towards operator.
- (c) Depress "START" button on push-button station.
- (d) Turn speed control lever to "LOW" until a low speed appears on the speedometer, then release.
- (e) Engage clutch by pushing shifter lever away from operator.
- (f) Depress button marked "HIGH" until desired high speed appears on the speedometer. Then, remove fingers from button.
- (g) Apply pressure as described under "PRESSURE CONTROL".

To stop the ironer, pull shifter lever towards operator, or push finger guard towards rear of

ironer. This permits the motor to continue running and ironer can be restarted by simply reengaging the clutch as described in paragraph (e) above.

To stop drive motor and vacuum-exhaustor motor, depress "STOP" button on the push-button station.

PRESSURE CONTROL

The operating lever at the right-hand side of the feed end of the ironer controls the power pressure mechanism.

To apply pressure on 6, 8 and 12-Roll Ironers, move lever to the left until pointer registers with indicating line marked "Ironing Pressure". Then return lever to neutral position.

To release pressure on 6, 8 and 12-Roll Ironers, move lever through neutral (*center position*), then to the right until pressure is released. A second pointer, at the right side of the pressure indicator, registers with fractional inch graduations from "0" (*indicating pressure "ON"*), to a 3-inch mark indicating that the rolls are raised maximum distance from the chests. Position of this pointer indicates distance the rolls are out of pressure.

Pressure may also be applied or released manually by turning the hand-wheel at the lower right feed end of the ironer. Turn the wheel counter-clockwise to apply pressure, and clockwise to release pressure.

Pressure control for 4-Roll Ironer is exactly the reverse of the above procedure.

IMPORTANT: *Never apply pressure to a cold machine while it is running.*

The pressure mechanism also raises and lowers the apron tension brackets at delivery end of ironer bringing the aprons into and out of contact with the steam chests.

To avoid burning padded roll covers, aprons and tapes, always release pressure when ironer is to be idle for ten (10) minutes or longer.

FEEDING

Never start feeding work into ironer until rolls and chests are thoroughly heated. Observe condition of work to make sure it is properly ex-

tracted. Excess moisture from under-extracted work will accumulate in the roll padding, causing unnecessary trouble and slowing down production.

When feeding large pieces, alternate them from end to end of the rolls. For example, large pieces at left end of rolls for a while, with smaller pieces alongside them, at the right. Then alternate, and feed large pieces at right end of rolls. When ironing small pieces only, they should be

fed along entire length of rolls.

Lubricate the steam chests at least once a day as described under "CLEANING CHESTS". This is essential for smooth travel of work through ironer.

Following these simple procedures will help keep the cover cloths straight, prolong the life of the padding, and result in better quality ironing.

ROUTINE MAINTENANCE

The unit has been built to give you long and trouble free service. In order to obtain the utmost in this, the machine must be given a certain amount

of care. Routine cleaning and lubrication is most important. Periodically the machine should be given a thorough inspection.

LUBRICATION CHART

HAND LUBRICATION - Refer to Figures 10, 11, 12 & 13

ITEM	APPLICATION	FREQUENCY	LUBRICANT	SUPPLIER
(A)	Grease Fittings	Every Week	Mobilplex EP#1 Alvania EP #2 Regal Starfak Prem 2 No. 88X Light Grease	Socony - Mobil Oil Co. Shell Oil Co. The Texas Co. Keystone Lubricating Co.
(B)	Oil Holes	Every Week	Mobil DTE Oil AA Shell Vitrea #74 Thuban Oil 90 SR #1 Oil	Socony - Mobil Oil Co. Shell Oil Co. The Texas Co. Keystone Lubricating Co.
(C)	Oil Boxes	Every Week	Mobil DTE Oil AA Shell Vitrea #74 Thuban Oil 90 SR #1 Oil	Socony - Mobil Oil Co. Shell Oil Co. The Texas Co. Keystone Lubricating Co.
(G)	Motor and Speed Reducer	See Manufacturer's Specifications		

TRABON LUBRICATION SYSTEM (Grease)

LUBRICANT	SUPPLIER
Mobilplex EP #1	Socony - Mobil Oil Co.
Shell Darina Gr. 2	Shell Oil Co.
Regal Starfak Prem. 2	The Texas Co.
No. 88X Light Grease	Keystone Lubricating Co.

BIJOR LUBRICATION SYSTEM (Oil)

LUBRICANT	SUPPLIER
Mobil DTE Oil AA	Socony - Mobil Oil Co.
Shell Vitrea #74	Shell Oil Co.
Texaco Thuban 90	The Texas Co.
S.R. #1 Oil	Keystone Lubricating Co.

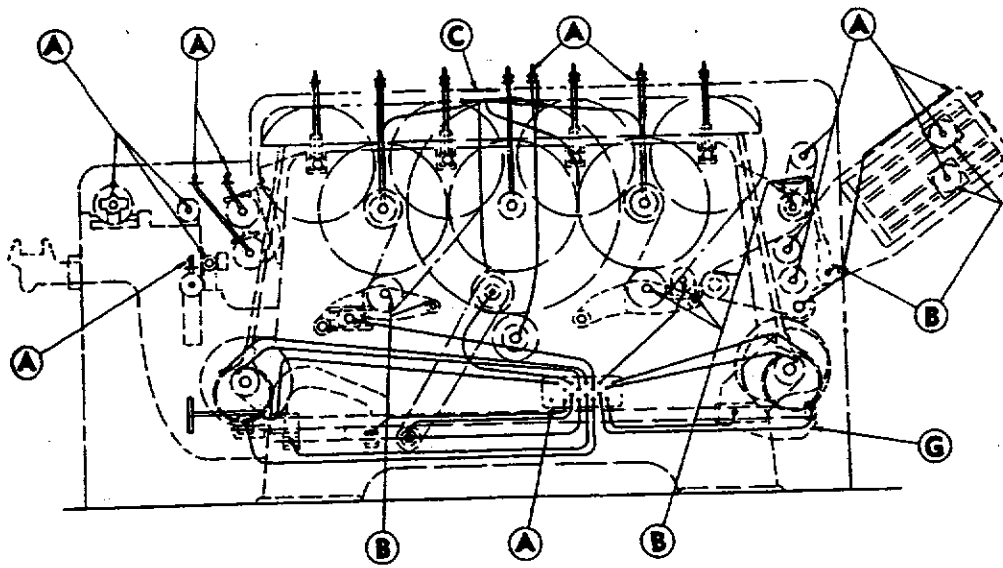

RIGHT HAND FRAME

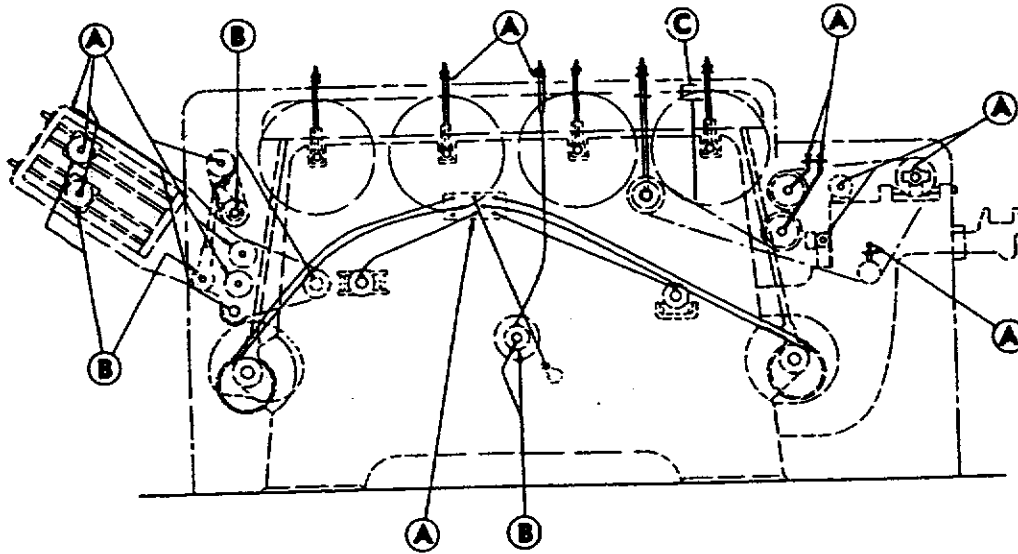

LEFT HAND FRAME

LUBRICATION OF POWER RAISING RIG
FOR 4-ROLL IRONER

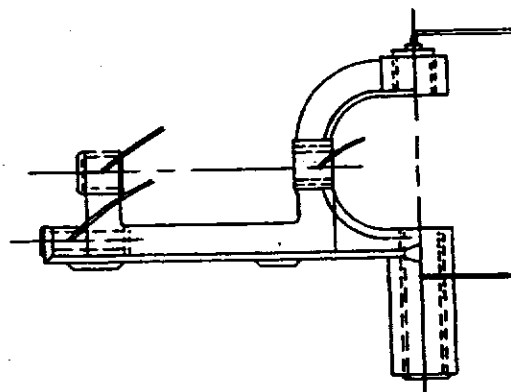
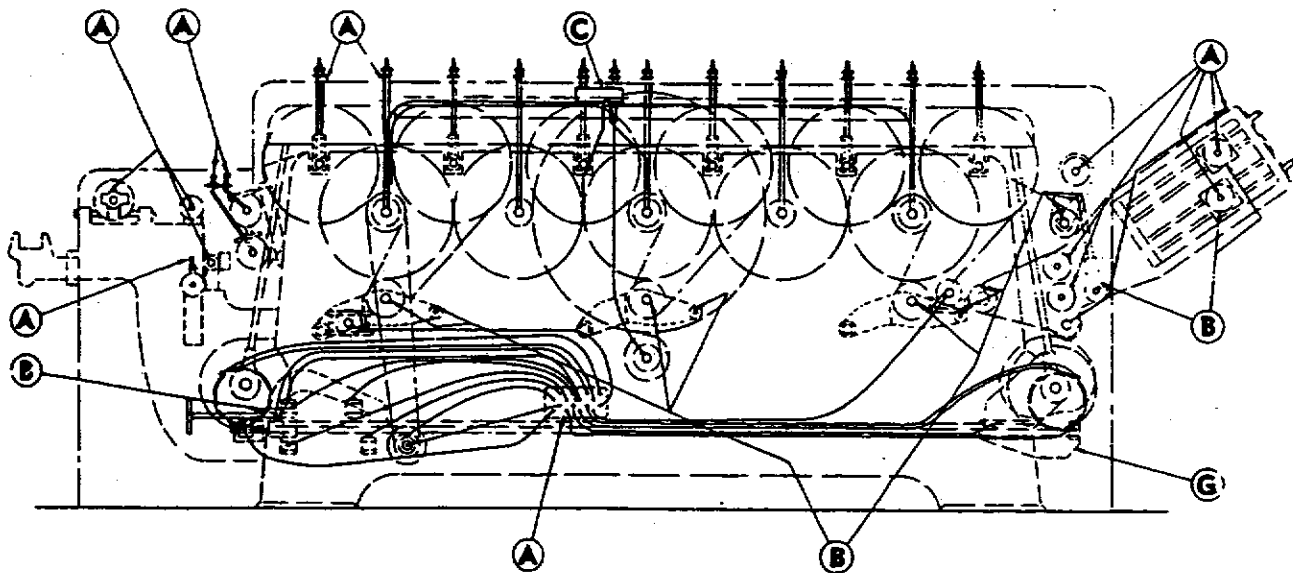
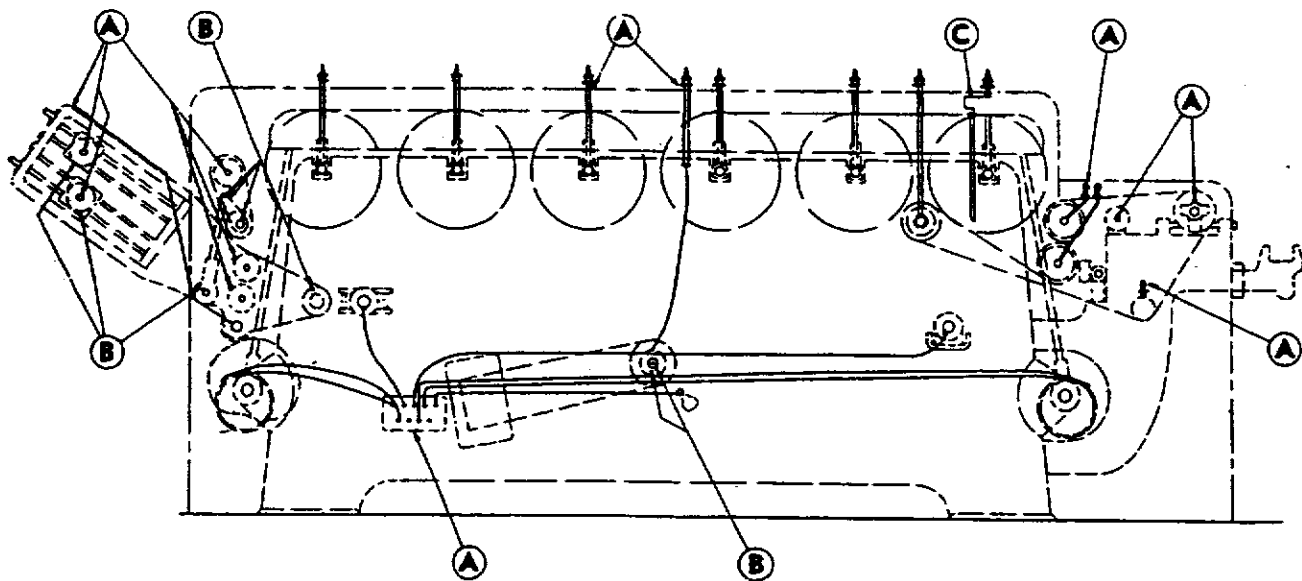

FIGURE 10 - 4-ROLL IRONER LUBRICATION DIAGRAM



RIGHT HAND FRAME



LEFT HAND FRAME

FIGURE 11 - 6-ROLL IRONER LUBRICATION DIAGRAM

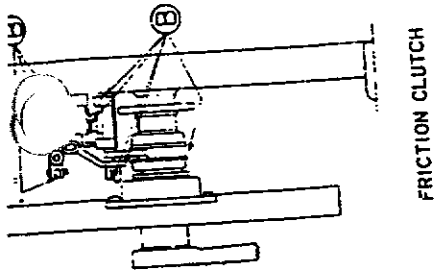

FRICTION CLUTCH

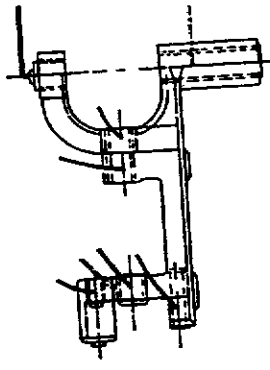

LUBRICATION OF POWER RAISING RIG FOR 6, 8 & 12 - ROLL IRONERS.

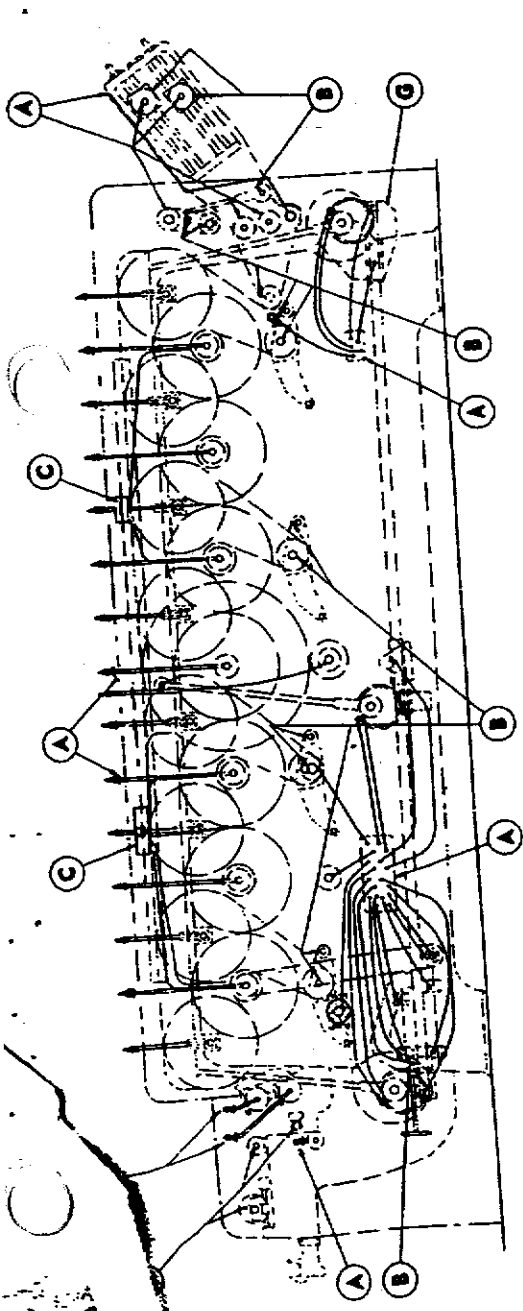

RIGHT HAND FRAME

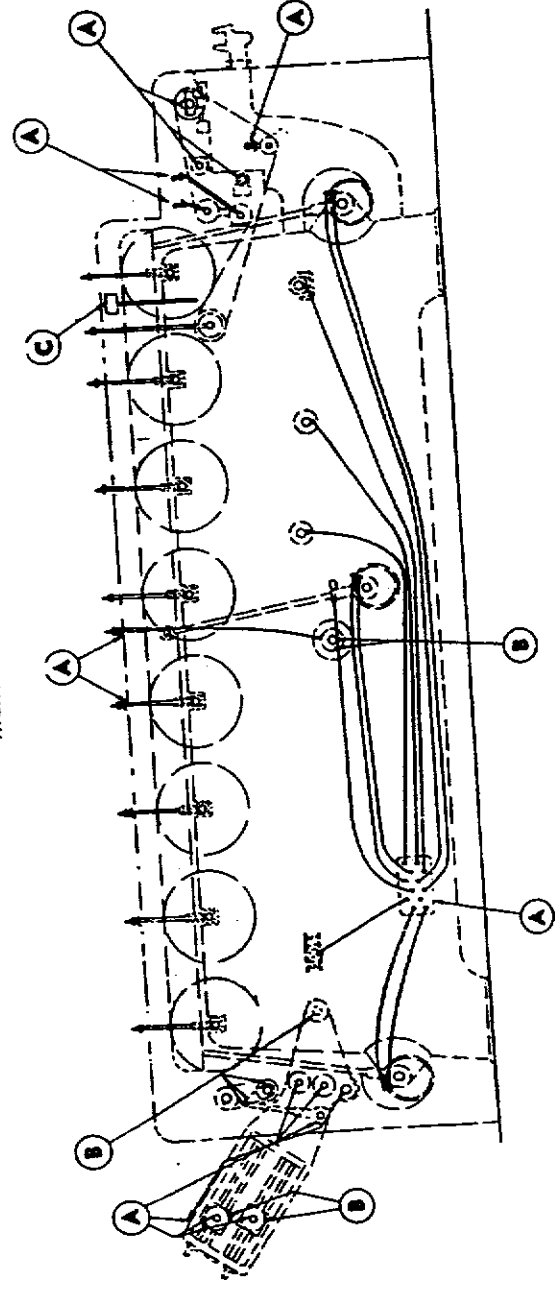

LEFT HAND FRAME

FIGURE 12 - 8 - ROLL-IRONER LUBRICATION DIAGRAM

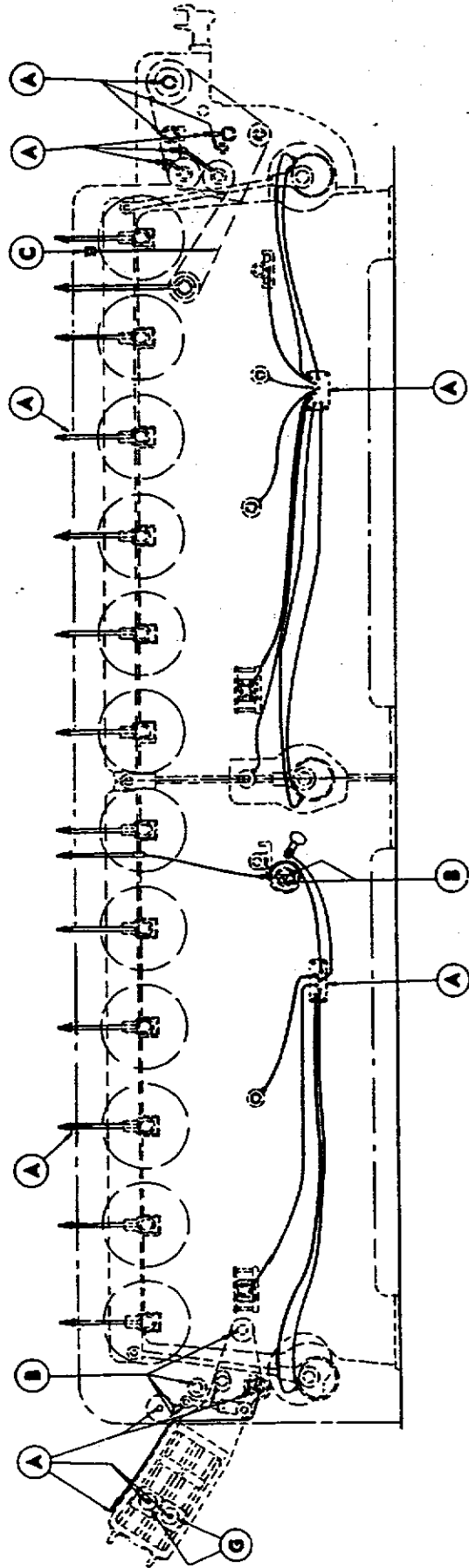
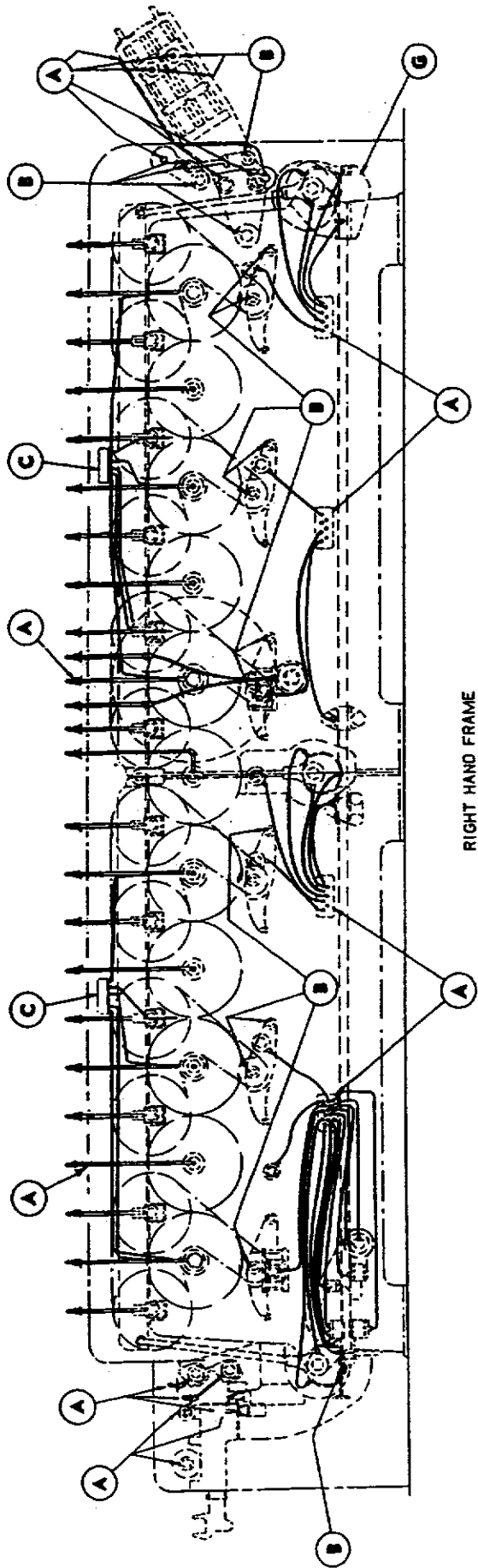

FIGURE 13 - 12-ROLL IRONER LUBRICATION DIAGRAM

CLEANING CHESTS

Important that flatwork ironer chests be kept clean and the ironing surface bright. Due to the fire hazard, kerosene or a kerosene soaked cloth should never be used to clean chests.

To clean the chests, saturate a muslin cloth, about the size of an ordinary sheet, with Trough Grease having a flash point of 375° F. or higher, and run the cloth through the ironer twice a week. Socony Mobil Oil Co. S.V. Trough Grease or Standard Oil Co. of Indiana Superla Trough Grease are recommended for this purpose.

The chests should also be kept lubricated by running a cloth, covered with type of Trough Grease recommended above, through the ironer each day. Use cloth 3 ft. wide and as long as the width of chests (100" or 120"). Using a putty knife, spread the Trough Grease on one half the width of cloth, then fold the other half of cloth over the greased half and feed cloth through the ironer folded edge first. This cloth can be used several times until the Trough Grease is exhausted, then it can be regreased.

INSPECTION

ELECTRICAL EQUIPMENT

Motor Maintenance - The motor should be inspected *weekly* in order to keep it in good operating condition. Keep the interior and exterior dry and free of dust, lint, grease or dirt. See that brushes of direct-current motors move freely in the holders and, at the same time, make firm and even contact with the commutator. In maintaining motors, cleanliness is of prime importance. Dirty windings may overheat and cause failure of the insulation. Windings may be cleaned by suction cleaners, compressed air or wiping. The compressed air should be free of moisture and the pressure should not be excessive. Nozzles of suction type cleaners should be non-metallic. Gummy deposits of dirt and grease may be removed by using carbon

tetrachloride. Terminal connections, assembly screws, bolts and nuts should be tight. They sometimes tend to loosen from vibration.

Motor Temperature - Motor temperature should be checked frequently by means of a thermometer. If the temperature is high, investigate the cause immediately. Motor temperature rise should not exceed temperature rise indicated on motor nameplate.

MISCELLANEOUS

The ironer should be inspected at regular intervals to make sure that:

- (a) Ironer is level. Frequently a floor or foundation will settle, and throw the ironer out of level. If the ironer is found to be out of level, it should be properly leveled and checked for square.
- (b) All nuts, bolts and screws are drawn tight.
- (c) Accumulated dust and lint are removed from machine and it is kept clean.
- (d) All steam and drain connections are not leaking, and trap or traps operate properly.
- (e) All moving parts are clean and properly lubricated.

The life of the padding can be lengthened considerably by giving it proper care. **NEVER run the ironer under pressure when the chests are cold.**

Do not increase the pressure too rapidly after re-padding, as this will pack the padding and cause it to lose its resiliency. Never use more pressure than is absolutely necessary to do good work.

Always release the pressure at noon and night, or any time when ironer is to be idle for more than ten minutes.

Always keep the chests well lubricated.

SPECIAL MAINTENANCE

INSTALLING CLIPPER LACE APRON

1. Stop ironer so that steel wire (which fastens ends of clipper-lace apron together) is at delivery end of machine.
2. Lower the spiral rolls as far as they will go, by turning the handle on the tension screws.
3. Remove the steel wire from the old apron.
4. Connect one end of new clipper-lace apron to the trailing end of the old clipper-lace apron with the steel wire.
5. Start ironer and run on lowest speed, guiding the new apron by hand until the leading end of the new apron is returned to delivery end.
6. Remove the steel wire and discard the worn apron.
7. Ironer aprons have blue guide lines woven into the fabric. Match up the guide lines where the two ends of the clipper-laced apron meet and insert steel wire through the clips.
8. Heat the steam chests.
9. Put machine in normal ironing pressure.
10. Take up on spiral rolls by turning tension screw handle until proper apron tension is obtained.

ADJUSTING CLUTCH (See Fig. 14)

The clutch is set when the ironer is first erected. It will probably not be necessary to change the setting for several years of operation. However, when the clutch wears to such an extent that adjustment is necessary, it is comparatively simple to make the adjustment.

Remove section of guard enclosing clutch. Then raise flat spring, and with a small screwdriver or centerpunch, move notched collar one notch in direction indicated, so that the flat spring will cover one more notch than it did formerly. It will usually be found that moving the notched collar one notch will be sufficient adjustment for several years operation.

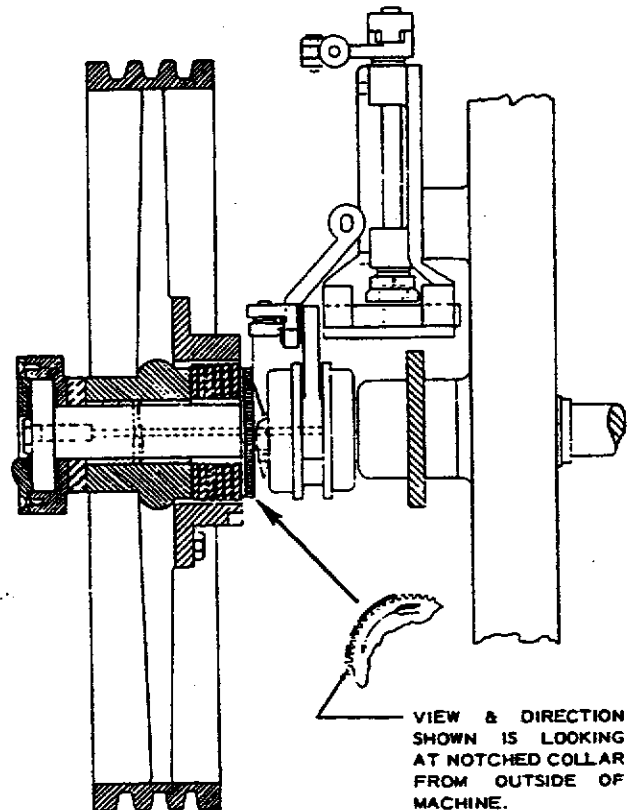

FIGURE 14 - CLUTCH ASSEMBLY

APRON ADJUSTMENT (See Fig. 15)

The aprons are automatically controlled or guided, by means of the American Automatic Apron Control Device. It consists of guide rolls, a system of connecting rods, bell cranks, and counterweights which connect the movable ends of the guide rolls with the corrugated friction spools on the spiral rolls.

The principle of this device is very simple, and can best be explained by comparing it with movement of a machine across the floor on skids and rollers. If movement of machine is in a straight line, the rollers must be set at exact right angles with the skids. If movement to the right or left of the straight line is required, position of the rollers is changed from a right angle. Comparing the Ironer apron to a machine on skids, and the guide rolls to the rollers beneath the machine, operation of the Automatic Apron Control Device will be readily understood.

The balance weights should be adjusted so they

will move the guide rolls freely when the aprons run off the friction spools. This is important in order to keep the aprons from having too much weight to lift when they run back onto the spools. After the ironer has been set as described above, the aprons will track very nicely, running off and on the friction spools very slowly.

However, if the aprons have a pronounced tendency to run toward one frame or the other, the following adjustment must be made:

- (1) Place yourself in a position facing the pivot end of the guide roll controlling the faulty apron.

- (2) Moving the pivot end of the guide roll to the *right* sends the apron to the spool-end of the spiral roll.
- (3) Moving the pivot end of the guide roll to the *left* sends the apron to the end opposite the spool-end of the spiral roll.

After making each adjustment, be sure to tighten the set screws on the bearings at pivot end of the guide rolls. Make all adjustments in increments of 1/2-inch, allowing time for apron to adjust itself to new position of the guide rolls.

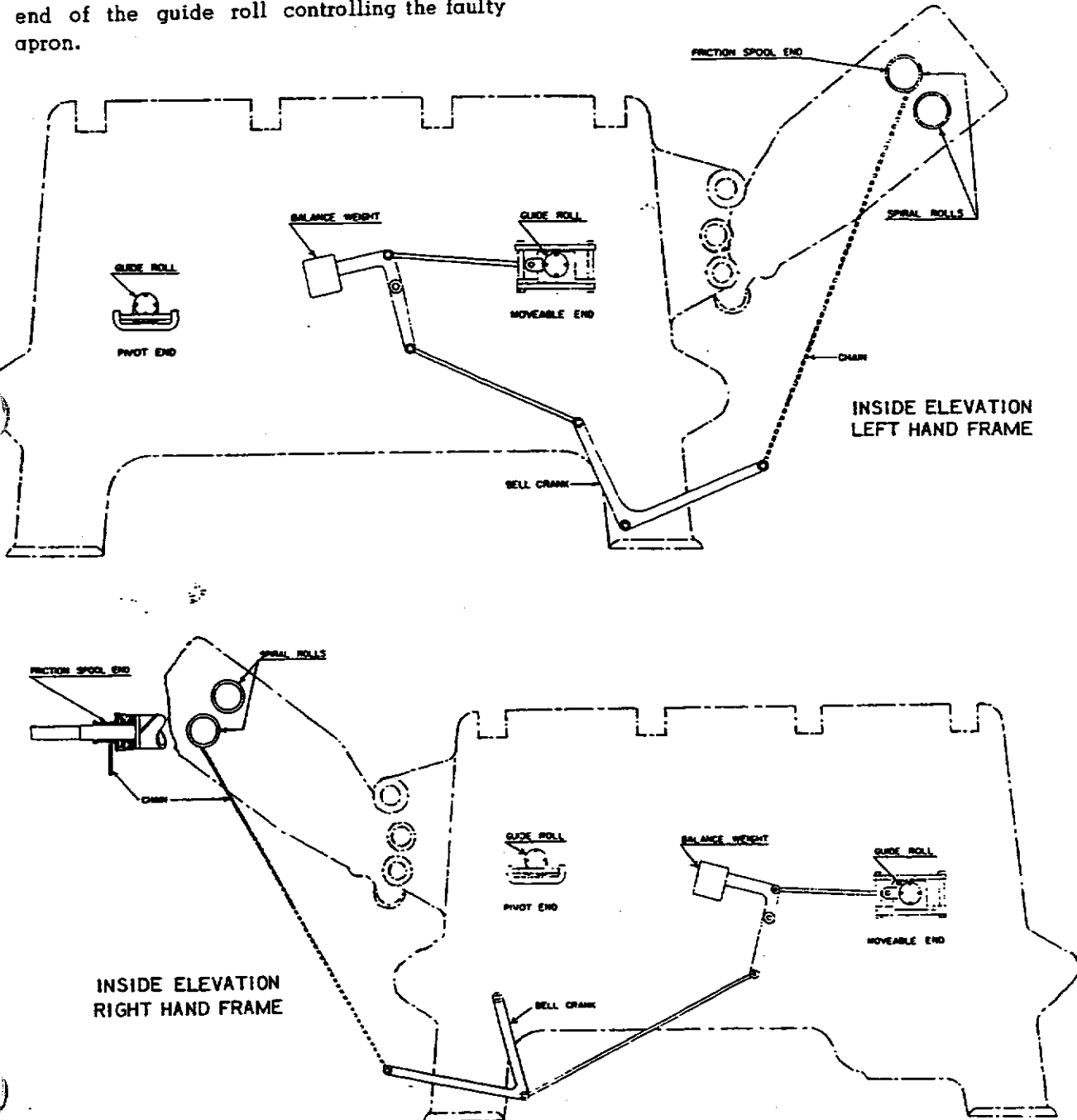

FIGURE 15 - APRON GUIDE ATTACHMENT

TROUBLE SHOOTING

SYMPTOM	POSSIBLE CAUSE	REMEDY
Linens buckling "Rolling"	<ul style="list-style-type: none"> (1) Steam chests insufficiently heated. (2) Steam chests dirty or insufficiently lubricated. (3) Flatwork improperly rinsed. (4) Excessive sour used. (5) Extraction not complete. (6) Rolls improperly graduated. 	<ul style="list-style-type: none"> (1) Heat steam chests thoroughly. (2) Lubricate chests. (3) Rinse work thoroughly. (4) Use proper amount of sour. (5) Lengthen extractor cycle. (6) Add covers to bring roll padding to proper circumference.
Aprons wrinkling	<ul style="list-style-type: none"> (1) Foundation has settled under one or more feet of the ironer, putting machine in a twist. (2) Apron guide mechanism not functioning properly. 	<ul style="list-style-type: none"> (1) Reinforce foundation. Properly level and square the ironer. (2) Check guide rolls to see that they move freely in their bearings. Check moveable ends of guide rolls to see that they are free in their guides. Check to see that chain from spool to the bell crank, also connecting rods from bell crank to weighted lever, and weighted lever to guide roll are free and move easily.
Linens sticking to rolls	<ul style="list-style-type: none"> (1) Steam chests insufficiently heated. (2) Flatwork improperly rinsed. 	<ul style="list-style-type: none"> (1) Heat steam chests thoroughly. (2) Rinse work thoroughly.
Ironers not delivering rated capacity	<ul style="list-style-type: none"> (1) Poor quality steam (<i>wet or low pressure</i>). (2) Return system not functioning properly. (3) Insufficient extracting. (4) Ironer running slow. 	<ul style="list-style-type: none"> (1) Check steam generating system. Ironer is designed to operate on dry, saturated steam at 125 pounds per square inch pressure (<i>gage</i>). (2) Inspect return system and remedy any defects. (3) Increase extracting time. It is more economical to remove excess water by proper use of extractor. (4) Check for belt slippage.

TROUBLE SHOOTING (CONT.)

SYMPTOM	POSSIBLE CAUSE	REMEDY
<p>Ironers not delivering Rated capacity (Cont.)</p>	<p>(5) Not enough ironing pressure. (6) Aprons too slack. (7) Work improperly fed to ironer. (8) Work improperly shaken out.</p>	<p>(5) Increase ironing pressure. (6) Tighten aprons. (7) Have feeders take advantage of all open spaces. Keep surface of rolls well covered with work. (8) Have shakers "shake out" work properly.</p>
<p>Aprons not traveling properly</p>	<p>(1) Apron guide mechanism not functioning properly. (2) Spiral rolls not paralleled to drive shaft. (3) Aprons too slack.</p>	<p>(1) Check guide rolls to see that they are moving freely in their bearings. Check movable end of rolls to see that they are free in guides. Check to see that chain from spool to bell crank, also rods from bell crank to weighted lever, and weighted lever to guide roll are free and move easily. (2) Keep spiral rolls parallel to drive shaft at all times. (3) Tighten aprons.</p>
<p>Padding pulls, covers wrinkle</p>	<p>(1) Decrease ironing pressure. (2) Feed work to ironer properly. (3) Lubricate chests. (4) Pad rolls properly.</p>	<p>(1) Excessive ironing pressure used. (2) Work improperly fed to ironer. (3) Steam chests dirty or insufficiently lubricated. (4) Rolls padded improperly.</p>

HOW TO ORDER REPAIR PARTS

When ordering repair parts, refer to the Parts Manual or Drawing furnished with the machine.

YOUR ORDER SHOULD INCLUDE:

NAME of your Machine.
SIZE of your Machine.
SERIAL NUMBER of your Machine.
 (Obtain from serial plate on machine.)

NAME of the Part.
ITEM NUMBER of the Part.
 (Obtain from Parts Manual or Drawing.)
QUANTITY of each Part.

NUMBER & DATE of Parts Manual or Drawing.

State how you want your order shipped:

- a - Freight, Express, Parcel Post, Air or Best Way.
- b - Prepaid, C.O.D. or Freight Collect.

FOR FASTEST SERVICE: All orders should be addressed to the office normally serving you!

Map below shows locations of our various offices from which repair parts can be ordered. Correct addresses of offices are given in opposite column.

EASTERN SALES DIVISION (Also Export)

40 East 34th St., New York 16, N.Y.
 27 Trinity Place, Boston 16, Mass.
 443 Delaware Ave., (Room 206), Buffalo 2, N.Y.
 239 Fairfield Ave., Upper Darby, Philadelphia, Pa.
 Stevenson Bldg., Center & Highland Avenues,
 Pittsburgh 6, Pa.
 1635 Connecticut Ave., N.W., Washington 9, D.C.

WESTERN SALES DIVISION

35 East Wacker Drive, Chicago 1, Illinois
 1118 Jackson Street, Dallas 2, Texas

SOUTHERN SALES DIVISION (& Gen'l Office)

Ross & Section Ave's., Cincinnati 12, Ohio
 1331 Spring Street, Atlanta 3, Georgia

PACIFIC SALES DIVISION

1600 Bryant Street, San Francisco 3, Calif.
 1442 E. Fourth Street, Los Angeles 33, Calif.
 105 Elliott Avenue, W., Seattle 99, Wash.

AMERICAN CLEANERS EQUIPMENT CO.

Ross & Section Avenues, Cincinnati 12, Ohio
 (For Dry Cleaning equipment which bears the ACECo Serial Plate, sold by the above Division of The American Laundry Machinery Company)

